

# SIRIO 150 / 150DV

## TECHNICAL REFERENCE

- Code 02B010 SIRIO 150
- Code 02B011 SIRIO 150DV with shutter

N°	PARTS DESCRIPTION	CODE NUMBER
3	Spot	SDM 90400010
4	Glass cover gasket	SDM 80320040
5	Wire protection gum	SDM 80000000
6	PG 7	SDM 80210005
7	PG 13	SDM 80210009
8	PFC plate	SDM 99020890
9	Power Factor Corrector	SDE 25000007
10	Electronic board	SDS 62990210
10/a	Electronic board (Minicity 150 shutter)	SDS 62990211
11	Bracket	SDM 90400011
12	Bracket screw	SDM 80000000
13	Connection box cover	SDM 90400012
14	Connection box gasket	SDM 80320050
15	Lamp support plate	SDM 99020810
16	Lamp socket complete	SDS 60990210
17	Spacer	SDM 80401595
18	Igniter	SDE 28621001
19	Igniter plate	SDM 99020820
20	Ballast	SDE 28515013
20/a	Ballast (Minicity150 shutter)	SDE 28515017
21	Thermal switch	SDE 34101100
22	Lamp	SDO 22101540
23	Connection cable	SDS 60990220
23/a	Connection cable (Minicity150 shutter)	SDS 60990225
30	Connection cable	SDS 60990230
31	Motor	SDE 42242032
32	Motor counterbalance	SDM 80400032
33	Spiral spring	SDM 80510710
34	Clutch	SDM 80300092
35	Color blade (magenta)	SDS 65990261
36	Color blade (magenta)	SDS 65990260
37	Color blade (yellow)	SDS 65990262
38	Color blade (yellow)	SDS 65990263
39	Color blade (cyan)	SDS 65990265
40	Color blade (cyan)	SDS 65990264
41	Color blade support	SDM 80400047
42	Motor connection board	SDS 60990240
42/a	Motor connection board (Minicity150 shutter)	SDS 60990235
43	Motor support plate	SDM 99010830
44	Reflector parabole	SDO 60000045
45	Parabole fixing screw	SDM 80000000
46	Color blade stop	SDM 80000000
47	Wall fixing plate	SDM 99020892
48	Nut	SDM 80000000
49	Upper shutter blade (Minicity150 shutter)	SDM 99020882
50	Lower shutter blade (Minicity150 shutter)	SDM 99020883
51	Aluminium cover	SDM 99020990
52	Cover screw	SDM 80000000
53	Tempered satin glass	SDO 52000025
54	Stop blades support	SDM 80400115
55	Stop screw	SDM 80000000
56	Light protection (aluminium cover)	SDM 99020888

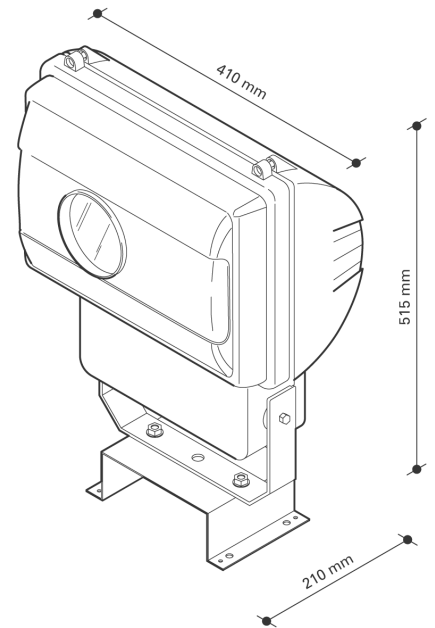

# Exploded view

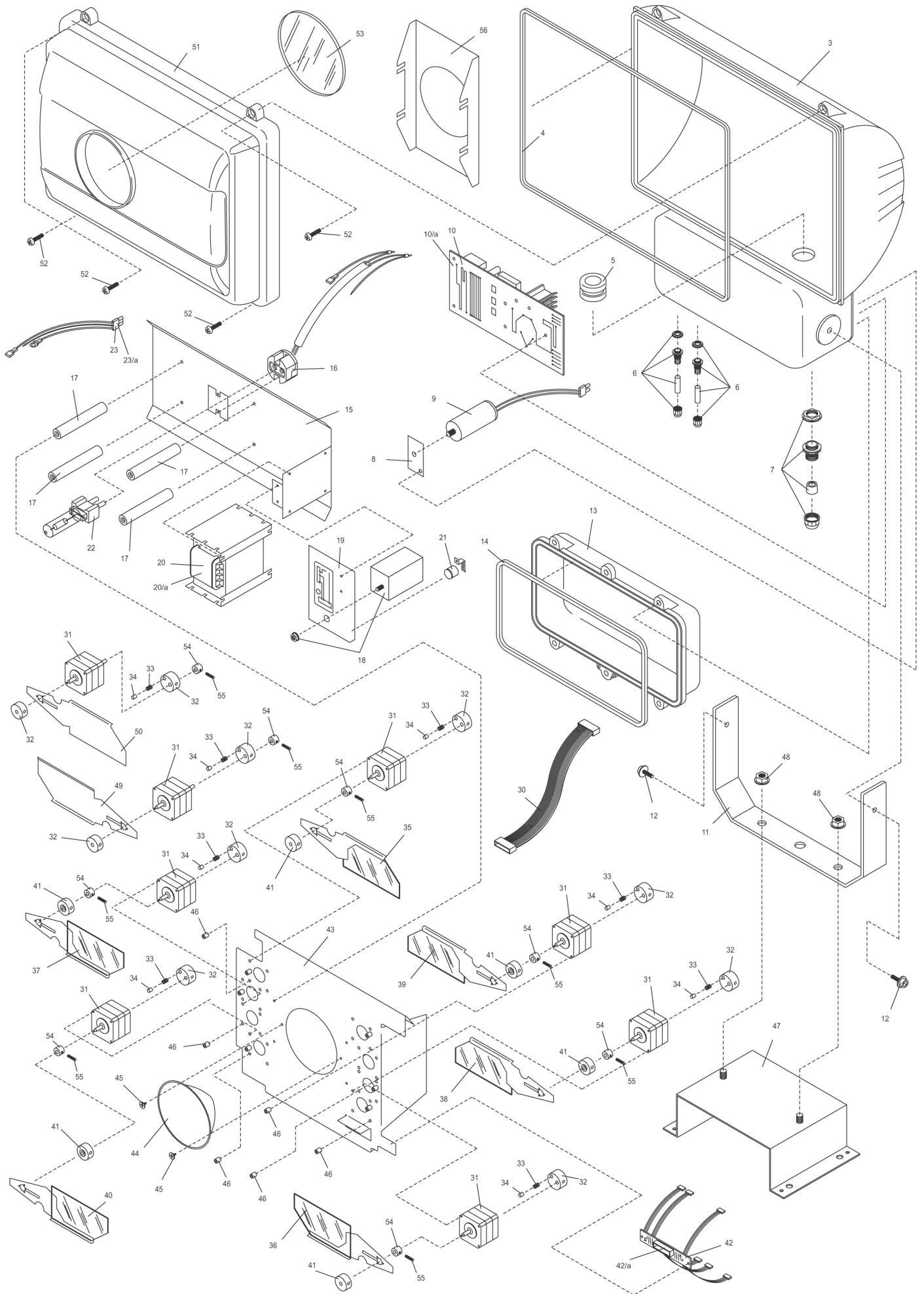

# Main Board 02B010

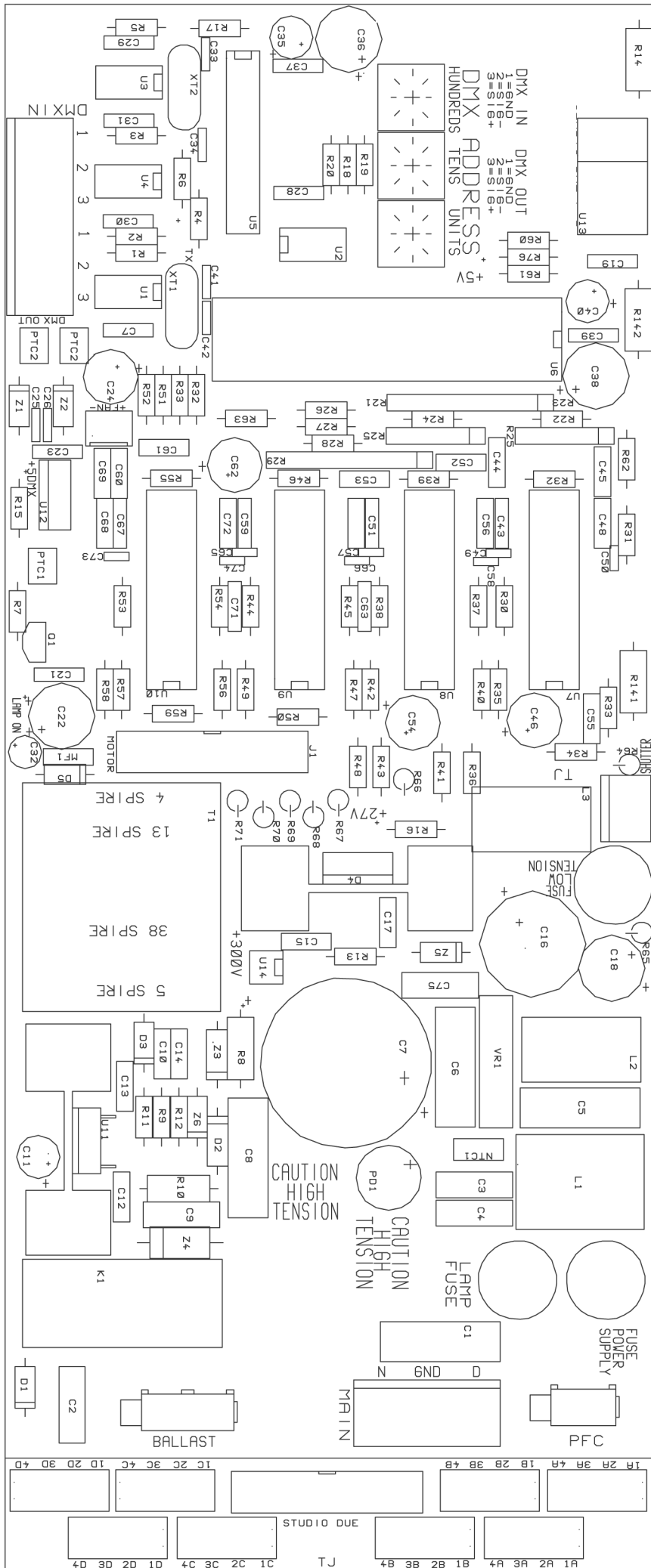

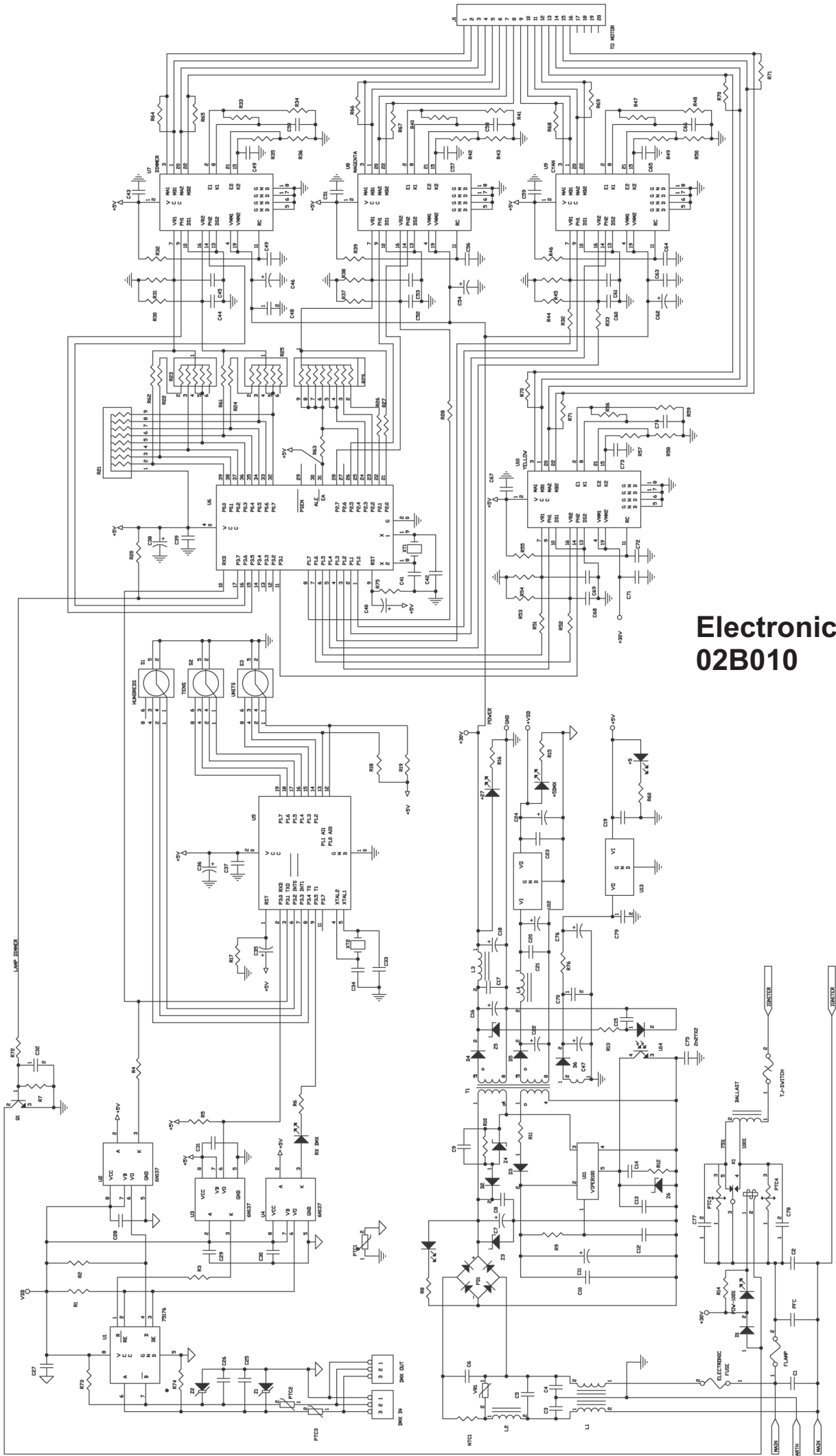

**Electronic Diagram  
02B010**

# Main Board 02B011

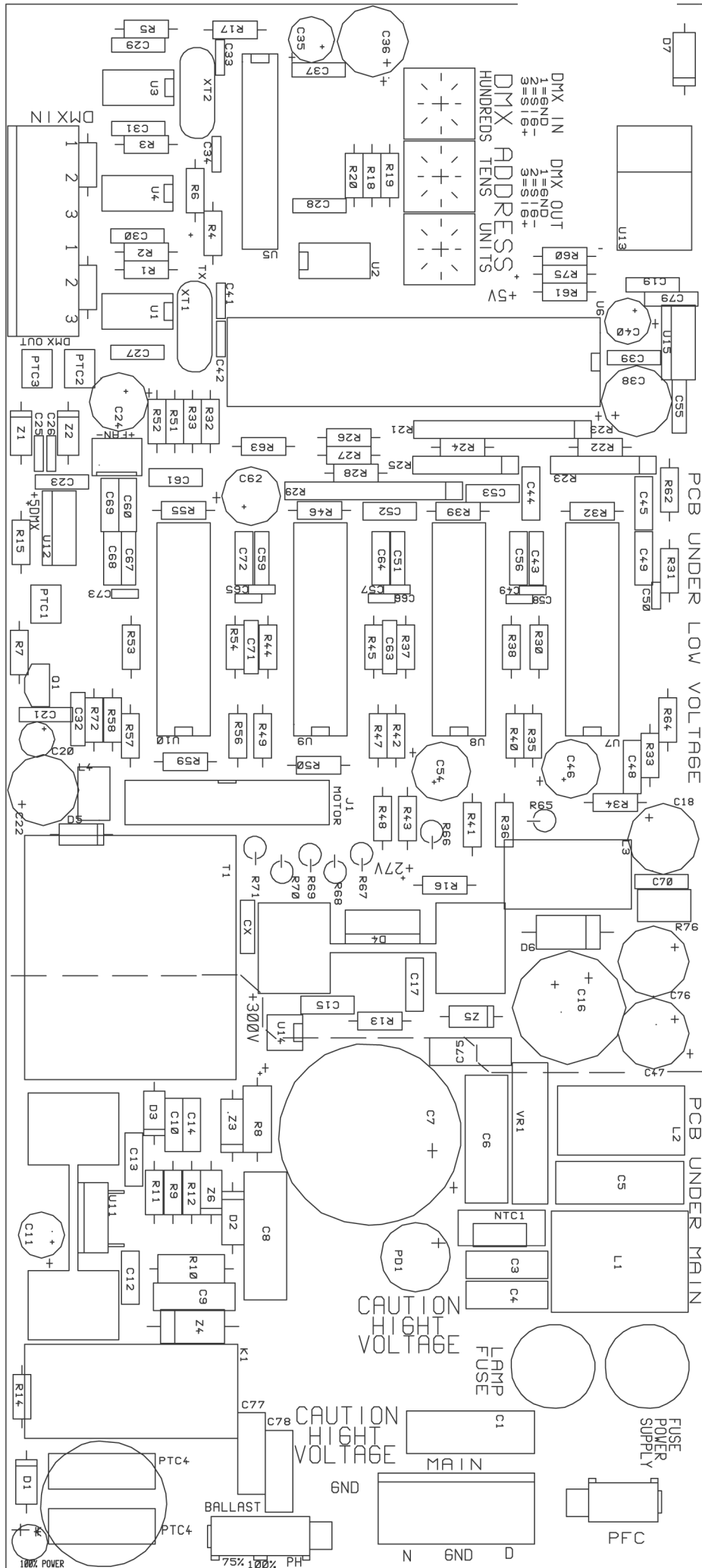

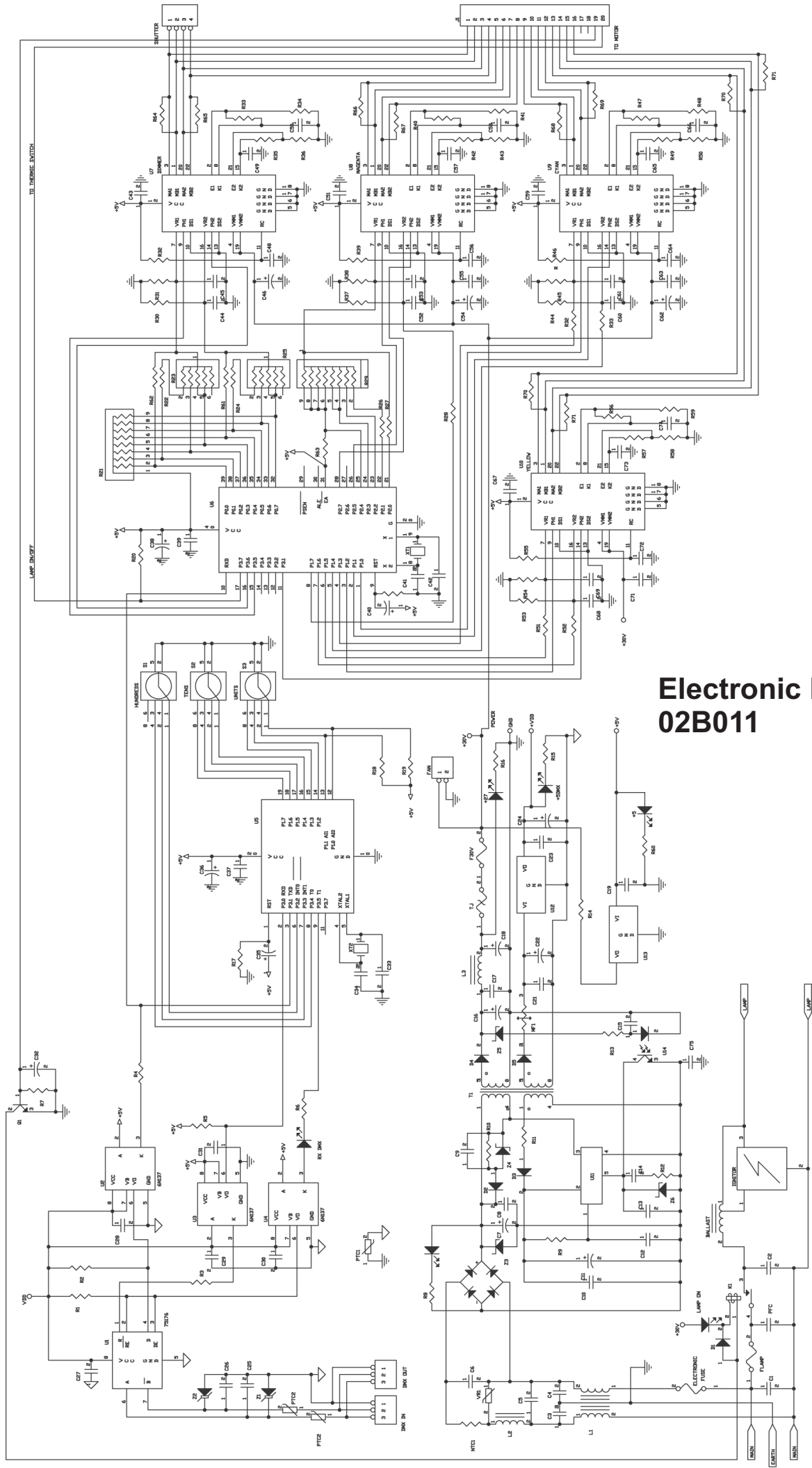

# Electronic Diagram 02B011